

3 601 F23 000

Issue } 13-03-26  
Stand }

Fig./Abb. 1

\* 12 = Typ . 000; . 030; . 060; . 070; . 0N0

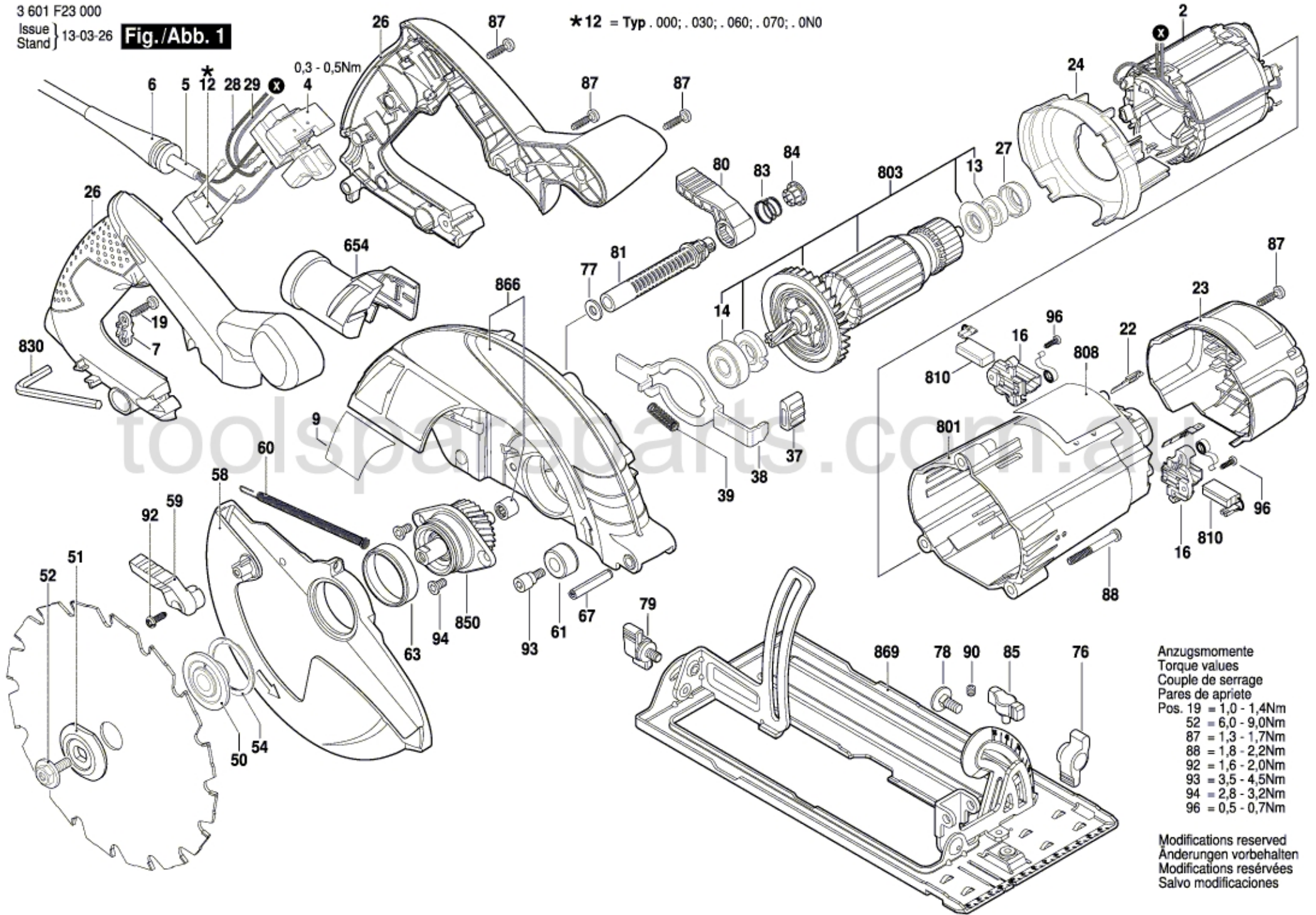

- Anzugsmomente  
Torque values  
Couple de serrage  
Pares de apriete
- |         |               |
|---------|---------------|
| Pos. 19 | = 1,0 - 1,4Nm |
| 52      | = 6,0 - 9,0Nm |
| 87      | = 1,3 - 1,7Nm |
| 88      | = 1,8 - 2,2Nm |
| 92      | = 1,6 - 2,0Nm |
| 93      | = 3,5 - 4,5Nm |
| 94      | = 2,8 - 3,2Nm |
| 96      | = 0,5 - 0,7Nm |

Modifications reserved  
Anderungen vorbehalten  
Modifications réservées  
Salvo modificaciones